



Titan™ PRO

32032

Elongated Front, RelaxedHeight™
12" [305mm] Rough-In, Two-Piece Toilet



Features

- Elongated Rim
- Top Rated Performance 1.6 gpf / 6.0 lpf
- RelaxedHeight™ 16-1/8" [410mm]
- Features the ProOne™ Flushing System
- High Volume 3" [76mm] Flush Valve with Chlorine-Resistant Flapper
- Extended Footprint for Easier Remodeling
- Brass Tank to Bowl Bolts
- 12" [305 mm] Rough-in
- 2-1/8" [54 mm] Fully Glazed Trapway
- Side Mount, Left Hand, Color-Matched, Trip Lever
- Concealed Sanitary Bar for Easy Cleaning
- Available in White, Bone, and Biscuit
- Ten-Year Worry-Free Limited Warranty



Toilet Seat Shown Not Included

Model

Description

32032	Elongated front, RelaxedHeight™ two-piece toilet combination with 3" [76 mm] flush valve. 12" [305 mm] rough-in. Includes side mount, left hand, color-matched, trip lever. Less toilet seat and supply.
32013	Elongated front, RelaxedHeight™ toilet bowl only. 12" [305 mm] rough-in. Less toilet seat.
32006	Tank and lid only with tank trim including 3" [76 mm] flush valve and side mount, left hand, color-matched, trip lever. Less supply.

Optional Tanks

32046	Insulated tank
32026	Triangle tank for corner installations

Optional Tank Levers / Toilet Seat

P33001100	Side Mount, Left hand, Trip Lever - White (Standard with White tanks)
P33001208	Side Mount, Left hand, Trip Lever - Bone (Standard with Bone tanks)
P33001251	Side Mount, Left hand, Trip Lever - Biscuit (Standard with Biscuit tanks)
P33001068	Side Mount, Left hand, Trip Lever - Polished Chrome
8080	Elongated, "Lift 'n' Clean", heavy-duty plastic, toilet seat

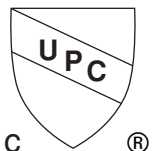

Specifications

Water Pressure Range: 20 to 80 P.S.I.

Flush System: ProOne™ Flushing System

Water Usage: 1.6 gpf /6.0 lpf

Water Surface Area: 9" x 11"
[229 mm x 279 mm]

Trap Diameter: 2-1/8" [54 mm]

Water Seal: 2-1/2" [64 mm]

Shipping Cubes:

32013 Bowl: 4.5 ft³ [.13m³]

32006 Tank: 1.95 ft³ [.05m³]

Shipping Weight:

32013 Bowl: 53 lbs. [24kg]

32006 Tank: 36 lbs. [16kg]

Warranty:

Ten-Year Worry-Free Limited Warranty

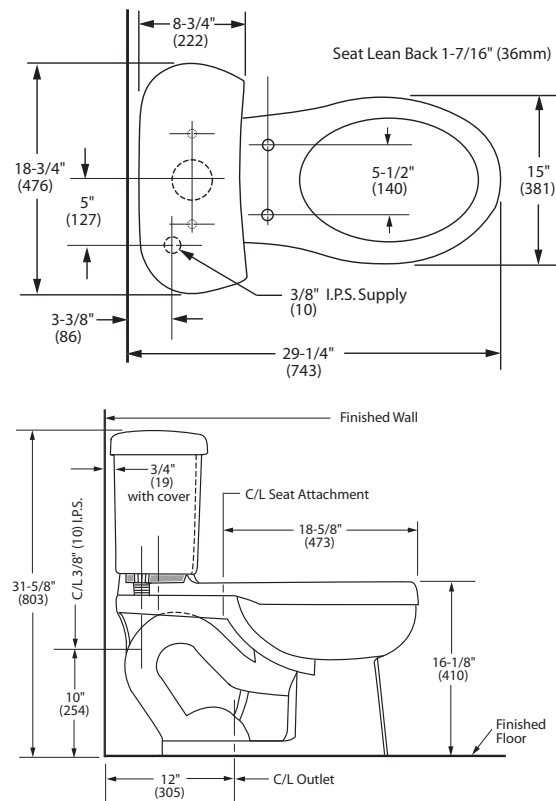

IMPORTANT: These dimensions are nominal and may vary within the range of tolerances established by ASME Standard A112.19.2

Features and Upgrades

- Extended Footprint easily covers existing floor gaps
- Stabilizer bars for rigid tank to bowl support
- Complies with ADA and CABO/ANSI A117.1 standards when installed in accordance with these standards.

Customer Service United States
41 Cairns Road
Mansfield, OH 44903
Email: customerservice@craneplumbing.com

www.cranepumbing.com

Customer Service Canada
15 Crane Ave.
Stratford, ON N5A 6T3
Email: sales@craneplumbing.ca

www.cranepumbing.ca

