



# Titan™ PRO

## 32022

Elongated Front  
12" [305mm] Rough-In, Two-Piece Toilet



### Features

- Elongated Rim
- Top Rated Performance 1.6 gpf / 6.0 lpf
- Features the ProOne™ Flushing System
- High Volume 3" [76mm] Flush Valve with Chlorine-Resistant Flapper
- Extended Footprint for Easier Remodeling
- Brass Tank to Bowl Bolts
- 12" [305 mm] Rough-in
- 2-1/8" [54 mm] Fully Glazed Trapway
- Side Mount, Left Hand, Color-Matched, Trip Lever
- Concealed Sanitary Bar for Easy Cleaning
- Available in White, Bone, and Biscuit
- Ten-Year Worry-Free Limited Warranty



Toilet Seat Shown Not Included

### Model #

### Description

32022	Elongated front, two-piece toilet combination with 3" [76mm] flush valve. 12" [305 mm] rough-in. Includes side mount, left hand, color-matched, trip lever. Less toilet seat and supply.
32008	Elongated front toilet bowl only. 12" [305 mm] rough-in. Less toilet seat.
32006	Tank and lid only with tank trim including 3" [76 mm] flush valve and side mount, left hand, color-matched, trip lever. Less supply.



### Optional Tanks

32046	Insulated tank
32026	Triangle tank for corner installations

### Optional Tank Levers / Toilet Seat

P33001100	Side Mount, Left hand, Trip Lever - White (Standard with White tanks)
P33001208	Side Mount, Left hand, Trip Lever - Bone (Standard with Bone tanks)
P33001251	Side Mount, Left hand, Trip Lever - Biscuit (Standard with Biscuit tanks)
P33001068	Side Mount, Left hand, Trip Lever - Polished Chrome
8080	Elongated, "Lift 'n' Clean", heavy-duty plastic, toilet seat

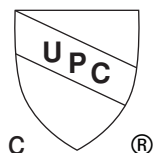

## Specifications

**Water Pressure Range:** 20 to 80 P.S.I.

**Flush System:** ProOne™ Flushing System

**Water Usage:** 1.6 gpf /6.0 lpf

**Water Surface Area:** 9" x 11"  
[229 mm x 279 mm]

**Trap Diameter:** 2-1/8" [54 mm]

**Water Seal:** 2-1/2" [64 mm]

**Shipping Cubes:**

32008 Bowl: 4.3 ft<sup>3</sup> [.95m<sup>3</sup>]

32006 Tank: 1.95 ft<sup>3</sup> [.05m<sup>3</sup>]

**Shipping Weight:**

32008 Bowl: 55 lbs. [2 kg]

32006 Tank: 36 lbs. [16kg]

**Warranty:**

Ten-Year Worry-Free Limited Warranty

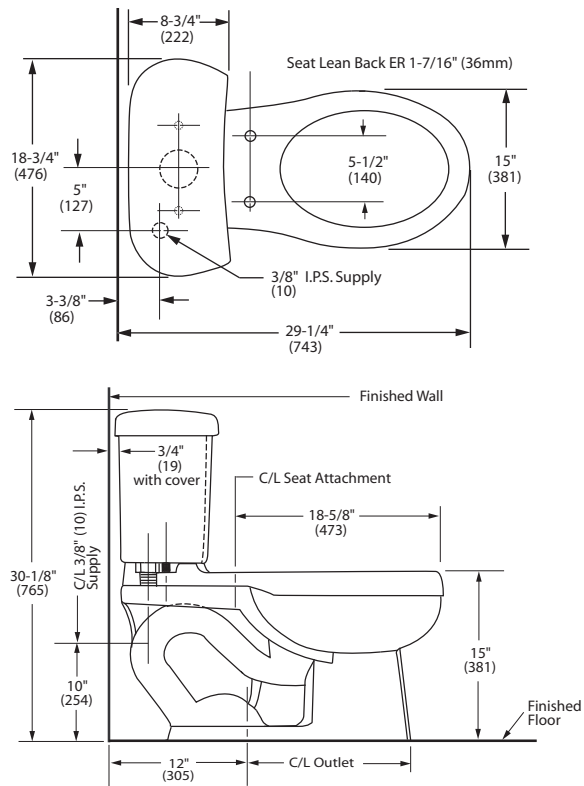

**IMPORTANT:** These dimensions are nominal and may vary within the range of tolerances established by ASME Standard A112.19.2

## Features and Upgrades

- Extended Footprint easily covers existing floor gaps
- Stabilizer bars for rigid tank to bowl support

Customer Service United States  
41 Cairns Road  
Mansfield, OH 44903  
Email: [customerservice@craneplumbing.com](mailto:customerservice@craneplumbing.com)

[www.cranepumbing.com](http://www.cranepumbing.com)

Customer Service Canada  
15 Crane Ave.  
Stratford, ON N5A 6T3  
Email: [sales@craneplumbing.ca](mailto:sales@craneplumbing.ca)

[www.cranepumbing.ca](http://www.cranepumbing.ca)

